

IGV-B0610



The **IGV-B0610** is an advanced high-speed progressive scan, fully programmable CCD camera designed for imaging applications that require high frame rates, high quality images, and powerful features and flexibility. The camera has a small size, light weight, and is built around Kodak's KAI-0340S Interline transfer CCD image sensor with a 1/3" optical format. IGV-B0610 is available with Ethernet output (GigEVision compliant).

The B0610 provides an image resolution of 648 x 488 and delivers up to 137 frames per second at full resolution. The camera image processing engine is based on a high-speed, high-density FPGA, featuring programmable resolution, speed, 8 independent AOIs, binning, triggering, exposure control, line and frame time, I/O mapping, external/internal sync, AGC, AEC, Auto Iris, transfer function correction, user LUT, and Defective and Hot Pixel Correction (DPC, HPC).

Features

- 648/640 x 488/480
- Mono and color - 8/10/12/14-bit data
- Normal and over-clock operation (110/137 fps)
- Ethernet output, GigEVision and Gen<l>Cam support
- Analog and digital gain and offset control
- 1x, 2x, 3x, 4x, 8x horizontal and vertical binning
- Eight (8) independent horizontal and vertical AOIs
- Programmable horizontal and vertical resolution
- Programmable line time, frame time and speed
- Programmable external trigger:
 - 3 triggering sources
 - 5 triggering modes
- Automatic gain, exposure and iris control

- Internal/External exposure control
- Internal/External H and V sync input/output
- Left/right digital bit shift
- Test image with image superimposition
- Built in pulse generator
- Programmable I/O mapping
 - 2 programmable inputs
 - 2 programmable outputs
- Dynamic transfer function correction
- Dynamic black level correction
- Defective and hot pixel correction
- Temperature monitor
- Field upgradeable firmware, LUT, DPC, HPC

Applications

- Industrial
- Medical
- Microscopy
- Military
- Scientific
- Surveillance

Specifications for Bobcat IGV-B0610

Maximum Resolution	648 x 488
Sensor Type	1/3" CCD KAI-0340
Pixel Size	7.40 um
Frame Rate	110/137 fps (normal/overclock)
Max Frame Rate	1600 fps
Minimum S/N ratio	60 db
Video output	RJ45 CAT 5e, CAT6
Output format	mono 8/10/12/16, mono 10/12 packed, bayer 8/10/12
Binning H & V	x1, x2, x3, x4, x8
Area of Interest	8 independent AOIs, 2 x 2 to 648 x 488
Shutter Speed	1/500000 to 1/110 sec
Long integration	Up to 16 sec
Gamma correction	G=1.0, G= 0.45, user upgradable LUT
Video gain	36 dB range, 1024 steps, 0.0351 dB per step
Exposure and AGC	Manual, Auto, Programmable
Iris Control	Auto, Programmable
Hardware trigger	LVTTTL or TTL via IN1/IN2, optically isolated, level, edge, pulse-width, programmable
Software trigger	Software, internal, level, edge, pulse-width, programmable
Trigger modes	Programmable, standard, double exposure, fast, frame accumulation, asynchronous
Strobe output	Programmable position and duration
Image Overlay	Yes, Programmable
RS232 Interface	Yes
Data Corrections	DPC, HPC, LUT
Min. illumination	1 Lux, F/1.4
Power input range	12 VDC, (10 V – 15 V)
Power consumption	4.2 W
Size (W x H x L), Weight	45 x 45 x 63mm, 243g
Lens Mount	C mount
Vibration, Shock	10G (20 - 200)Hz XYZ, 70G
Environmental	Operation (-30° to 60°) C, storage (-40° to 70°) C
Humidity	10% to 90% non-condensing

Power and I/O Interface

Connector: Hirose HR 10A-10R-12PB(71)

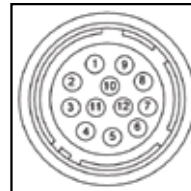

1	12V DC Return	7	OUT1 Signal
2	+12V DC	8	IN1 Signal
3	IRIS VCC	9	IN2 Signal
4	IRIS Video	10	IN1/2 Return
5	IRIS Return	11	Spare
6	OUT1/2 Return	12	OUT2 Signal

Power Requirements

12V DC, (10V min, 15V max)
300 mA steady, 1.5 A inrush
3.6 W

Accessories

PS12V04: Power Supply (sold separately)
PS12V05 Power Supply with Auto Iris (sold separately)

Ordering Information

Ordering: **IGV-B0610M-KC0**

Camera Family

B-Bobcat Family

Sensor Type

M-Monochrome

C-Color

Lens Mount

C-“C” mount (default)

F-“F” Mount

CCD

K-Kodak

Spectral Response

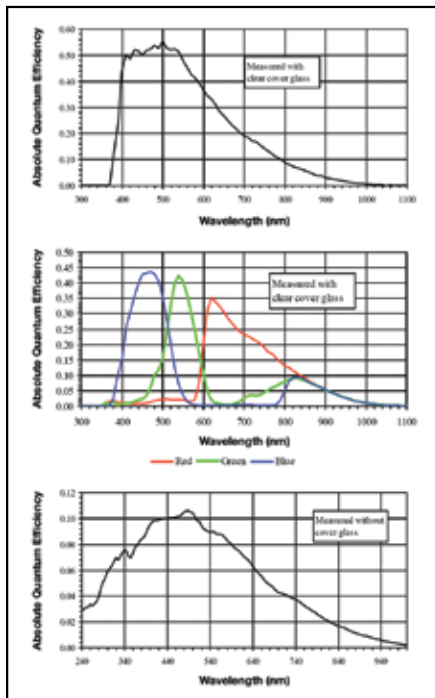

Software/Drivers/Interface

GigE Protocol: 10/100/1000 Mb/s, 802.3, Ethernet v2.0, IPv4, IGMPv.2, UPD and ICMP

Drivers for: Windows 2000/XP/XP-64/Vista32/Vista64/Win 7-32/Win 7-64/SuSE 10/RedHat 5/ and others

Software: GigE Vision Player

SDK: C++GigE Vision Software Developers Kit

Support for: Labview, ImagePro, Halcon, MIL, eVision, CommonVision, StreamPix, CoreView, Streams5, Absoft Active GigE, and others

Multicast capable

Mechanical Dimensions

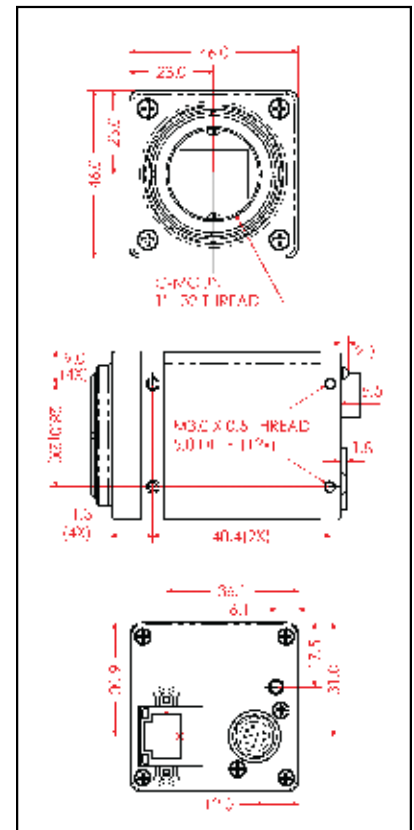

For specific details and ordering information, consult the camera user's manual or contact us at sales@imperx.com.

Copyright © 2009, Imperx, Inc. Product information subject to change without notice. Rev. 1.0, 04/30/10



Imperx Incorporated • 6421 Congress Avenue • Boca Raton, FL 33487 • USA
Phone: +1-561-989-0006 • 1-866-849-1662 • Fax: +1-561-989-0045
www.imperx.com • sales@imperx.com

