

MV-CH1010-10CM

101 MP CMOS Camera Link Area Scan Camera



GEN<i>i>CAM



Introduction

MV-CH1010-10CM camera adopts Sony® IMX461 sensor to provide high-quality images. It uses Camera Link interface to transmit non-compressed images in real time, and its max. frame rate can reach 8.1 fps in full resolution.

Key Feature

- Supports auto or manual adjustment of gain and exposure time, and manual adjustment of LUT and Gamma correction.
- Supports FFC correction function.
- Supports 16-bit ADC output with high acquisition accuracy and wide dynamic range.
- Provides camera with fan or TEC to meet different working temperature requirements.
- Supports configuration modes of Base, Medium, Full and 80-bit via the Camera Link interface.
- Compatible with Camera Link V2.0 Protocol, GenICam Standard, and the frame grabber software meeting with GenICam Protocol.

Available Model

- Mono camera with fan: MV-CH1010-10CM-M72-NF
- Mono camera with TEC: MV-CH1010-10CM-M72-TF

Applicable Industry

FPD detection, PCB AOI, file scanning, etc.

Sensor Quantum Efficiency

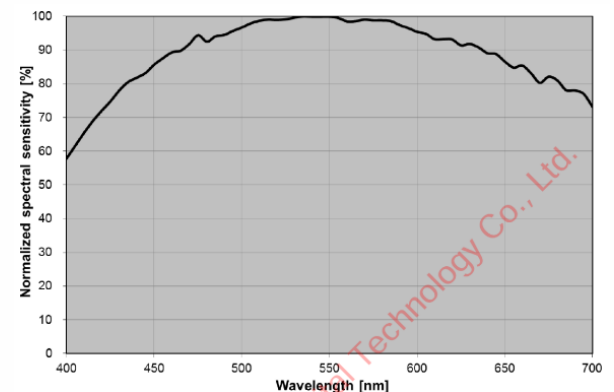

Specification

Model	MV-CH1010-10CM
Camera	
Sensor type	CMOS, rolling shutter
Sensor model	Sony® IMX461
Pixel size	3.76 μm × 3.76 μm
Sensor size	55 mm
Resolution	11648 × 8740
Max. frame rate	8.1 fps @11648 × 8740
Configuration mode	Base, Medium, Full, 80-bit
Tap geometry	2X_1Y, 4X_1Y, 8X_1Y, 10X_1Y
Tap number	2 Taps, 4 Taps, 8 Taps, 10 Taps
Pixel clock	40 MHz, 60 MHz, 70 MHz, 85 MHz
Dynamic range	78 dB
SNR	45 dB
Gain	0 dB to 36 dB
Exposure time	14 μs to 10 sec
Exposure mode	Off/Once/Continuous exposure mode, supports Global Reset
Mono/color	Mono
Pixel format	ADC 12-bit mode: Mono 8/10/12; ADC 16-bit mode: Mono 8/10/12/16
Binning	Supports 1 × 1, 1 × 2, 1 × 4, 2 × 1, 2 × 2, 2 × 4, 4 × 1, 4 × 2, 4 × 4
Decimation	Supports 1 × 1, 1 × 2, 1 × 4, 2 × 1, 2 × 2, 2 × 4, 4 × 1, 4 × 2, 4 × 4
Reverse image	Supports horizontal reverse image output
Electrical feature	
Data interface	Camera Link with SDR interface
Digital I/O	12-pin P10 connector provides power and I/O, including opto-isolated input × 1 (Line 0), opto-isolated output × 1 (Line 1), bi-directional non-isolated I/O × 1 (Line 2), and RS-232 × 1. Camera Link interface provides I/O (CC1/CC2/CC3/CC4)
Power supply	Camera with fan: 12 VDC to 24 VDC Camera with TEC: 24 VDC
Power consumption	Camera with fan: Typ. 14 W@24 VDC Camera with TEC non-cooling: Typ. 14 W@24 VDC Camera with TEC cooling: Typ. 48 W@24 VDC
Mechanical	
Lens mount	M72*0.75, flange focal length 19.55 mm
Dimension	Camera with fan: 90 mm × 90 mm × 71.5 mm (3.5" × 3.5" × 2.8") Camera with TEC: 100 mm × 100 mm × 87.2 mm (3.9" × 3.9" × 3.4")
Weight	Camera with fan: Approx. 790 g (1.7 lb.) Camera with TEC: Approx. 1.7 kg (3.7 lb.)
Ingress protection	IP40 (under proper lens installation and wiring)
Temperature	Working temperature: 0 °C to 50 °C (32 °F to 122 °F) Storage temperature: -30 °C to 70 °C (-22 °F to 158 °F)
Humidity	20% to 95% RH, non-condensing
General	
Client software	MVS or frame grabber software meeting with GenICam Protocol
Operating system	32/64-bit Windows 7/10
Compatibility	Camera Link V2.0, GenICam
Certification	CE, RoHS, KC

Dimension

Camera with fan:

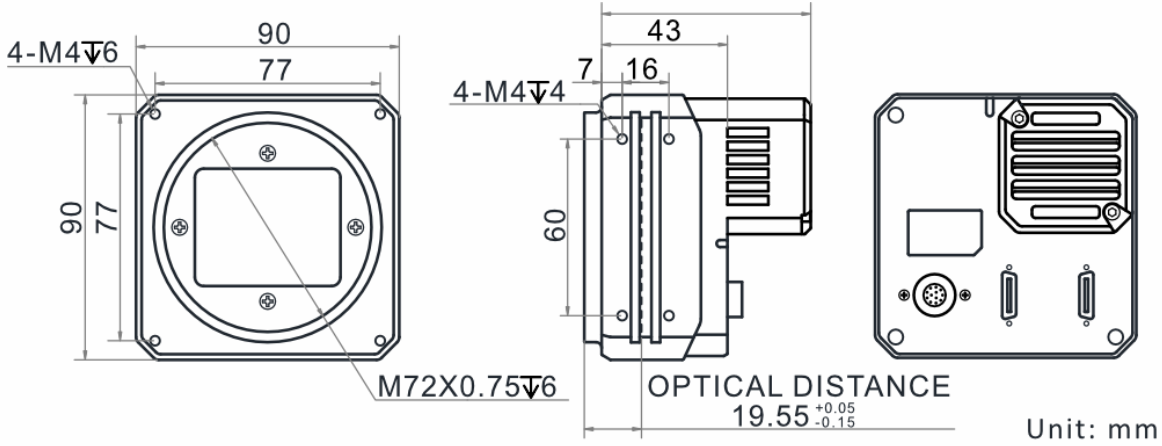

Camera with TEC:

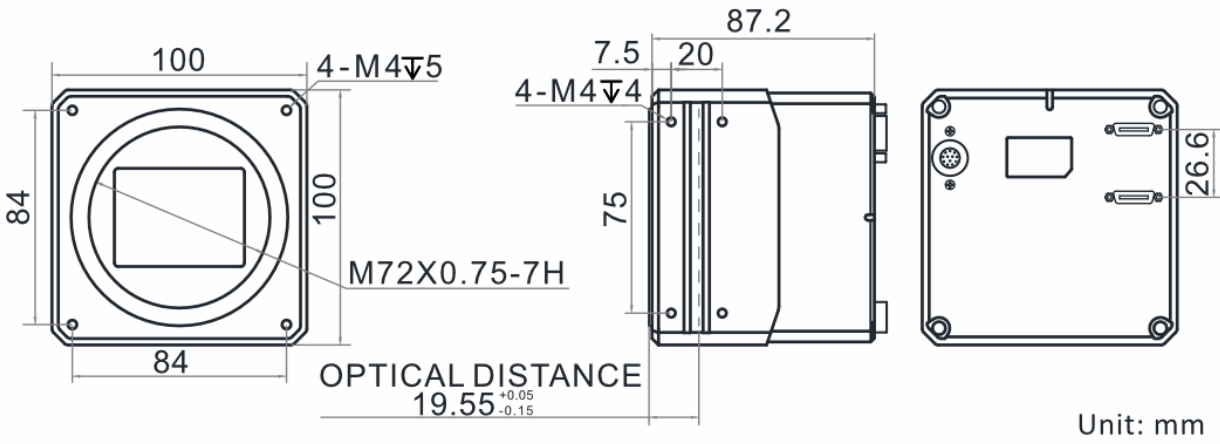

HIKROBOT

Hangzhou Hikrobot Co., Ltd.
en.hikrobotics.com