



a TKH Vision brand

EXO USB3 Vision

exo174MU3

The SVCam EXO is one of the most flexible and scalable cameras for the industrial market segment. The USB3 Vision interface is easy to integrate in your system, with a data rate up to effective 360 MB/sec. The time to market for applications is shortened, saving cost even further. Power the camera via the interface and reduce cable complexity.

Technical Highlights

- Up to 360 MB/s effective transfer rate
- Leverages existing infrastructure for cables and connectors
- Powers camera with up to 4.5 W
- GenICam compliant
- Cost effective / Easy implementation and interfacing



LED
4 INTEGRATED
LED-CONTROLLERS

SEQ
INTEGRATED
SEQUENCER

STT
SAFE TRIGGER
TECHNOLOGY

PLC
PROGRAMMABLE
LOGIC CONTROL

CHAT WITH US



Specifications

Resolution [MP]	2.3 MP
Resolution (h x v)	1920 x 1200 px
Frame rate(max.)	160 fps
Chroma	mono
Interface	USB3.0 (Micro-B)

Sensor

Sensor	IMX174LLJ
Manufacturer	Sony
Sensor type	Area CMOS
Shutter type	global shutter
Sensor size (h x v)	11.25 x 7.03 mm
Optical diagonal	13.27 mm
Sensor format	13.4mm (Type 1/1.2)
Pixel size (h x v)	5.86 x 5.86 μ m

Camera

Exposure modes	MANUAL;AUTO;EXTERNAL
Trigger modes	INTERNAL;SOFTWARE;EXTERNAL
Exposure time (min)	19 μ s
Exposure time (max)	60 sec (external ∞)
Pixel format / max	mono8, mono12packed / 12 bit
Gain modes / max	manual, auto / 18 dB
S/N ratio (max)	44 dB (dep. on environment)
Dynamic range (max)	72 dB (dep. on environment)
Internal memory	256 MB SDRAM, 32 MB Flash

Feature Set

AOI	yes
LUT	yes
Offset	yes
Binning	yes
Image flip	yes
Shading correction	yes
Defect pixel correction	yes
Sequencer	yes

Housing

Lens mount	C-Mount
Dimensions (w x h x d)	50 x 50 x 42.7 mm
Weight	140 g
Operating temperature (housing)	-10 to 60 $^{\circ}$ C
Ambient humidity	10 to 90 % (non-condensing)
Protection class	IP40
Filter-/Coverglass	K9 - AR coating - 400-850nm

I/O-Interfaces

Input up to 24V	2 x
Input OPTO	1 x
Output open drain	4 x
I/O RS-232	1 x
Power supply	10 to 25 V (DC)
Power consumption	4.5 W (dep. on operating mode)

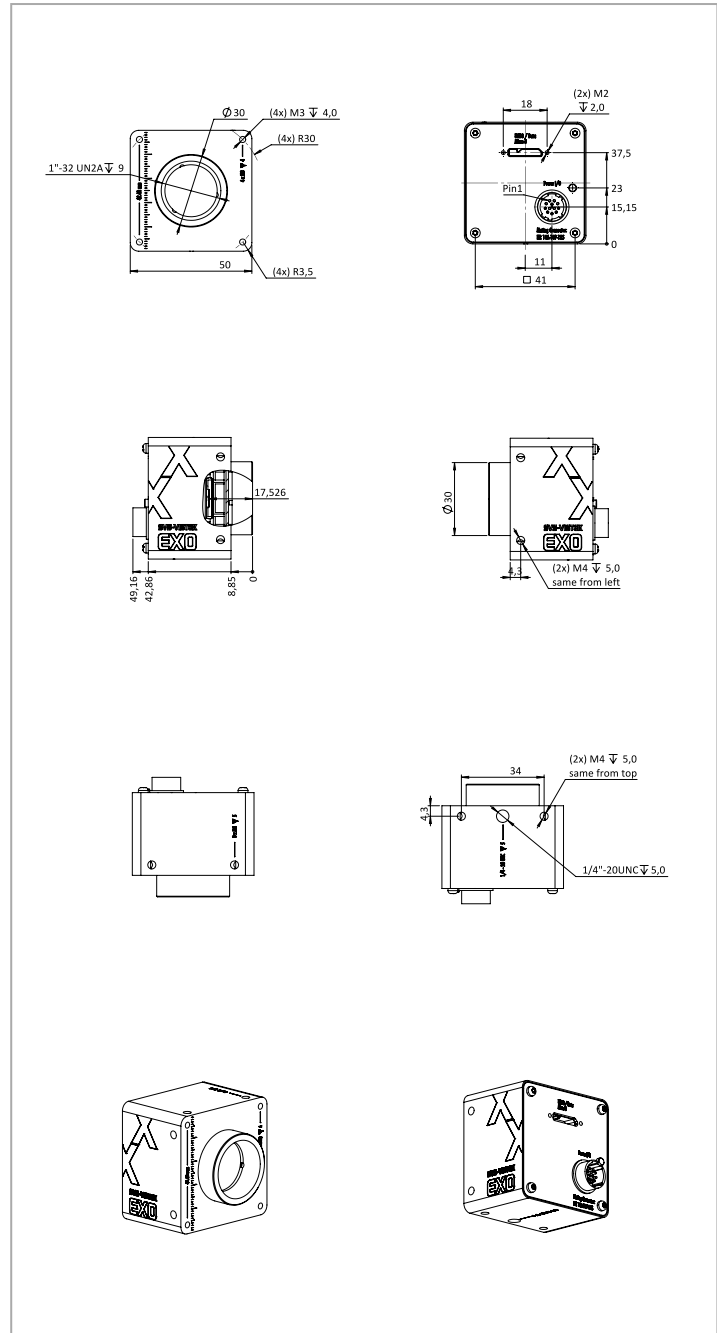

Pinout Mating Connector

Hirose 12 Pin	1	VIN - (GND)	7	OUT1 (open drain)
	2	VIN + (10 V to 25 V DC)	8	OUT2 (open drain)
	3	IN 4 (RXD RS232)	9	IN 3 + (opto In +)
	4	OUT 4 (TXD RS232)	10	IN 3 - (opto In -)
	5	IN 1 (0 - 24V)	11	OUT 3 (open drain)
	6	IN 2 (0 - 24V)	12	OUT 0 (open drain)

Spectral Response *

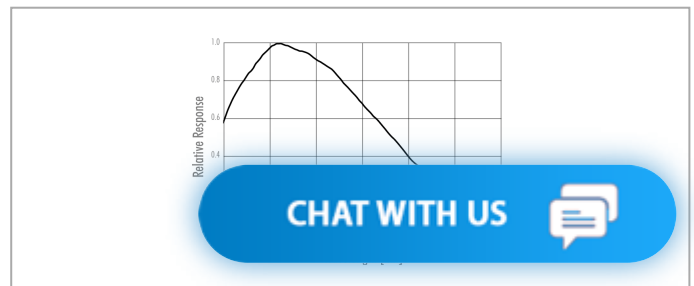

* Sensor data – excludes camera cover- or IR-cut filter characteristics

SVS-VISTEK GMBH

Ferdinand-Porsche-Str. 3 82205 Gilching Germany phone +49 8105 3987-60 info@svs-vistek.com

© 2024–2025 SVS-Vistek GmbH

CHAT WITH US

