

HR CoaXPress

hr65MCX12

CoaXPress transmits up to 6.25Gbit/s per line for CoaXPress-6 interfaces and even 12.5Gbit/s for the CoaXPress-12 interface. The Interface also supports long data lines. CXP lines can be operated in parallel. The high bandwidth of current CMOS sensors can therefore be optimally utilized.

The fan can be fully deactivated via software and features a hermetic seal that isolates airflow from internal components, ensuring compatibility with critical cleanroom environments. Optional heatsinks help keep your camera in optimal operating conditions.

Technical Highlights

With its high-resolution CMOS sensors from Sony, Gpixel and ON Semi, the HR CoaXPress delivers outstanding frame rates and offers a wide range of industrial hardware and software features.

- ROI, LUT, Binning, Offset
- Lens shading correction
- Integrated multi-channel LED strobe controller
- CoaXPress-6 or CoaXPress-12
- Industrial TTL-24V I/O interface with SafeTrigger, programmable logic functions, sequencer, timer, RS232
- Power over CXP
- Ideal for cleanrooms



Specifications

Resolution [MP]	65 MP
Resolution (h x v)	9344 x 7000 px
Frame rate(max.)	71 fps
Chroma	mono
Interface	CXP-12 with 4 Connections (micro-BNC)

Sensor

Sensor	GMAX3265
Manufacturer	Gpixel
Sensor type	Area CMOS
Shutter type	global shutter
Sensor size (h x v)	29.9 x 22.4 mm
Optical diagonal	37.36 mm
Sensor format	37.4mm
Pixel size (h x v)	3.2 x 3.2 μm

Camera

Exposure modes	MANUAL;AUTO;EXTERNAL
Trigger modes	INTERNAL;SOFTWARE;EXTERNAL
Exposure time (min)	12 μs
Exposure time (max)	60 sec (external ∞)
Pixel format / max	mono8, mono10 / 10 bit
Gain modes	manual, auto
S/N ratio (max)	40 dB (dep. on environment)
Dynamic range (max)	65.6 dB (dep. on environment)
Internal memory	1024 MB SDRAM, 160 MB Flash

Feature Set

AOI	yes
LUT	yes
Offset	yes
Binning	yes
Image flip	yes
Shading correction	yes (external)
Defect pixel correction	yes
Sequencer	yes

Housing

Lens mount	M58x0.75
Dimensions (w x h x d)	70 x 70 x 76.3 mm
Weight	420 g
Operating temperature (housing)	-10 to 60 °C
Ambient humidity	10 to 90 % (non-condensing)
Protection class	IP30
Filter-/Coverglass	N-BK7 - AR coating

I/O-Interfaces

Input up to 24V	2 x
Input OPTO	1 x
Output open drain	4 x
I/O RS-232	1 x
Power supply	10 to 25 V (DC)
Power consumption	18 W (dep. on operating mode)

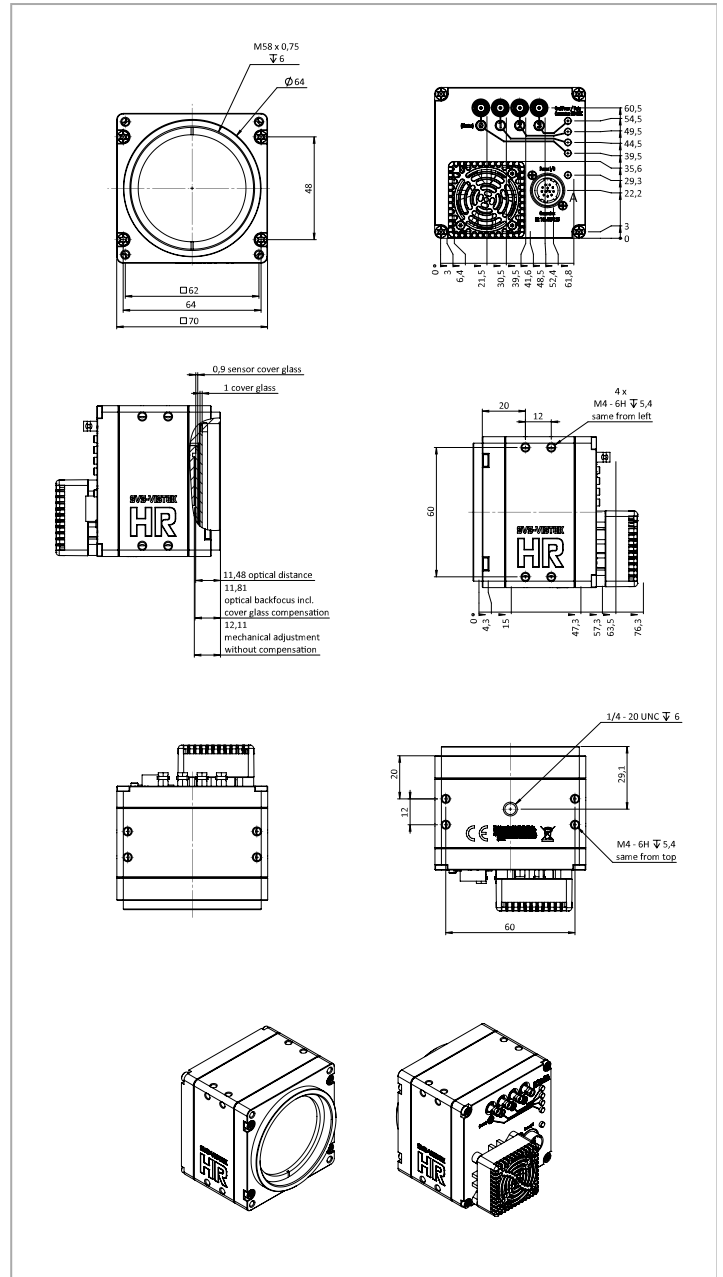

Pinout Mating Connector

Hirose 12 Pin	1	2	3	4	5	6	7	8	9	10	11	12
	VIN -	VIN +	IN 4	OUT 4	IN 1	IN 2	OUT 1	OUT 2	IN 3 +	IN 3 -	OUT 3	OUT 0
	(GND)	(10 V to 25 V DC)	(RXD RS232)	(TXD RS232)	(0 - 24V)	(0 - 24V)	(open drain)	(open drain)	(opto In +)	(opto In -)	(open drain)	(open drain)

Spectral Response *

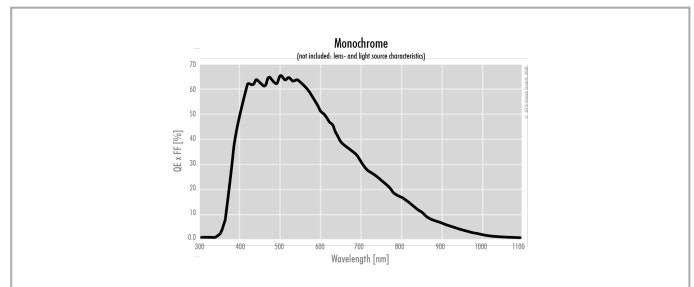

* Sensor data - excludes camera cover- or IR-cut filter characteristics

