

SHR CoaXPress-6

shr461CCX

- **Highest resolution made in Germany**

The SHR series combines large pixel structures with the highest resolutions. The physical characteristics of large pixels guarantee outstanding image quality. High-quality harmonization of the pixels with defect pixel correction provides a noise-free image. The camera offers the highest structural precision in sensor adjustment in a massive, thermally highly optimized housing. The large M72 lens mount can be adapted to any lens. This makes the SHR the camera for the most demanding optical tasks.

The high-performance CoaXPress interface enables the fastest high-speed data transfer with excellent latency behavior. The camera is equipped with a comprehensive I/O interface with galvanic interface separation, sequencer and integrated multichannel LED light control.

The fan can be fully deactivated via software and features a hermetic seal that isolates airflow from internal components, ensuring compatibility with critical cleanroom environments. Optional heatsinks help keep your camera in optimal operating conditions.

Technical Highlights

- Outstanding image quality
- High dynamic range
- Excellent harmonization of the pixels
- CMOS sensors with rolling and global shutter
- User-defined lens shading correction
- Signal security through Schmitt trigger, debouncer
- Industrial I/O concept: up to 24 V signal voltage, RS232, galvanically isolated input
- Integrated multichannel LED strobe controller
- Sequencer - up to 16 intervals
- GenICam interface
- Ideal for cleanrooms

CoaXPress specific features

- Quad CoaXPress-6
- Power over CoaXPress



The SHR is ideal for inspecting larger areas, in the CoaXPress version also with long data lines. Ideal for wafer, solar panel and display inspection applications.

Specifications

Resolution [MP]	101.8 MP
Resolution (h x v)	11648 x 8742 px
Frame rate (max.)	8.7 fps
Chroma	color
Interface	CXP-6 with 4 Connections (Din1.0/2.3)

Sensor

Sensor	IMX461LOA
Manufacturer	Sony
Sensor type	Area CMOS
Shutter type	rolling shutter
Sensor size (h x v)	43.8 x 32.87 mm
Optical diagonal	54.76 mm
Sensor format	55mm (Type 3.4)
Pixel size (h x v)	3.76 x 3.76 μ m

Camera

Exposure modes	MANUAL;AUTO
Trigger modes	INTERNAL;SOFTWARE;EXTERNAL
Exposure time (min)	60 μ s
Exposure time (max)	60 sec
Pixel format / max	bayer8, bayer10, bayer12, bayer16 / 16 bit
Gain modes / max	manual, auto / 36 dB
S/N ratio (max)	46.8 dB (dep. on environment)
Dynamic range (max)	81.3 dB (dep. on environment)
Internal memory	512 MB SDRAM, 160 MB Flash

Feature Set

Manual white balance	yes
Automatic white balance	yes
AOI	yes
LUT	yes
Offset	yes
Binning	yes
Image flip	yes
Shading correction	yes (external)
Defect pixel correction	yes
Sequencer	yes
PoCXP	yes

Housing

Lens mount	M72x0.75
Dimensions (w x h x d)	80 x 80 x 83 mm
Weight	580 g
Operating temperature (housing)	-10 to 70 °C
Ambient humidity	10 to 90 % (non-condensing)
Protection class	IP30
Filter-/Coverglass	Borofloat B270i - AR coating

I/O-Interfaces

Input up to 24V	2 x
Input OPTO	1 x
Output open drain	4 x
I/O RS-232	1 x
Power supply	10 to 25 V (DC)
Power consumption	14 W (dep. on operating mode)

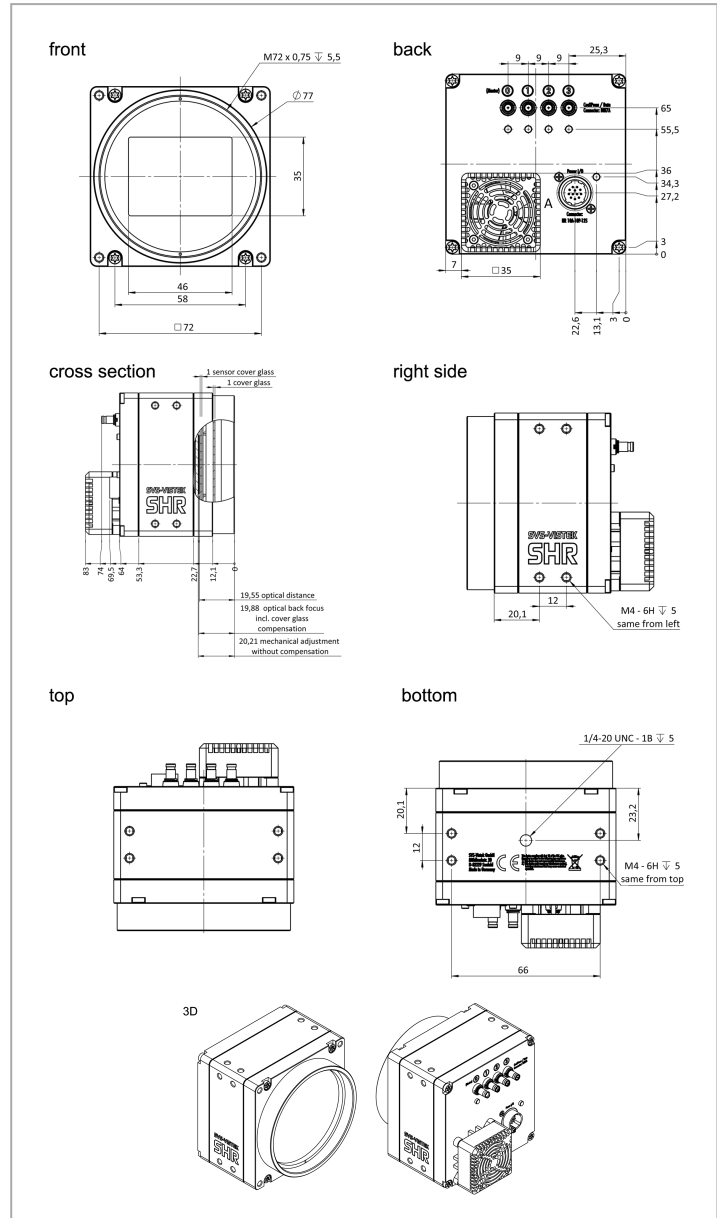

Pinout Mating Connector

	1	VIN - (GND)	7	OUT 1 (open drain)
	2	VIN + (10 V to 25 V DC)	8	OUT 2 (open drain)
	3	IN 4 (RXD RS232)	9	IN 3 + (opto In +)
	4	OUT 4 (TXD RS232)	10	IN 3 - (opto In -)
	5	IN 1 (0 - 24V)	11	OUT 3 (open drain)
	6	IN 2 (0 - 24V)	12	OUT 0 (open drain)

Spectral Response *

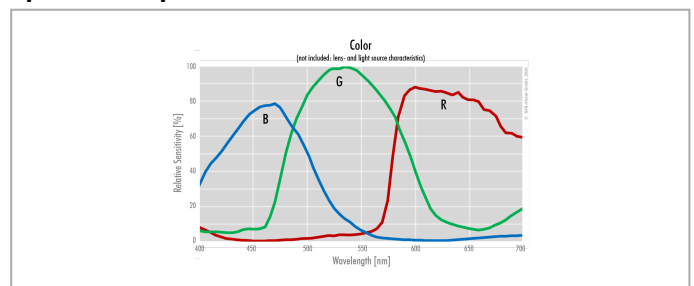

* Sensor data – excludes camera cover- or IR-cut filter characteristics

SVS-VISTEK GMBH

© 2024–2025 SVS-Vistek GmbH

Ferdinand-Porsche-Str. 3 82205 Gilching Germany phone +49 8105 3987-60 info@svs-vistek.com