

SHR CoaXPress-12

shr661MCX12

Highest resolution made in Germany

The SHR series combines large pixel structures with the highest resolutions. The physical characteristics of large pixels guarantee outstanding image quality. High-quality harmonization of the pixels with defect pixel correction provides a noise-free image. The camera offers the highest structural precision in sensor adjustment in a massive, thermally highly optimized housing. The large M72 lens mount can be adapted to any lens. This makes the SHR661 and SHR811 the cameras for the most demanding optical tasks.

The high-performance CoaXPress interface enables the fastest high-speed data transfer with excellent latency behavior. The camera is equipped with a comprehensive I/O interface with galvanic interface separation, sequencer and integrated multichannel LED light control.

The fan can be fully deactivated via software and features a hermetic seal that isolates airflow from internal components, ensuring compatibility with critical cleanroom environments. Optional heatsinks help keep your camera in optimal operating conditions.

Technical Highlights

- Outstanding image quality
- High dynamic range
- Excellent harmonization of the pixels
- CMOS sensors with rolling and global shutter
- User-defined lens shading correction
- Signal security through Schmitt trigger, debouncer
- Industrial I/O concept: up to 24 V signal voltage, RS232, galvanically isolated input
- Integrated multichannel LED strobe controller
- Sequencer - up to 16 intervals
- GenICam interface
- Ideal for cleanrooms

CoaXPress specific features

- Can be operated with Dual and Quad CoaXPress-12 or CoaXPress-6
- Power over CoaXPress



The SHR is ideal for inspecting larger areas, in the CoaXPress version also with long data lines. Ideal for wafer, solar panel and display inspection applications.

Specifications

Resolution [MP]	127.6 MP
Resolution (h x v)	13392 x 9528 px
Frame rate (max.)	20.3 fps
Chroma	mono
Interface	CXP-12 with 4 Connections (micro-BNC)

Sensor

Sensor	IMX661LLA
Manufacturer	Sony
Sensor type	Area CMOS
Shutter type	global shutter
Sensor size (h x v)	46.2 x 32.87 mm
Optical diagonal	56.7 mm
Sensor format	56.73mm (Type 3.6)
Pixel size (h x v)	3.45 x 3.45 μm

Camera

Exposure modes	MANUAL;AUTO;EXTERNAL
Trigger modes	INTERNAL;SOFTWARE;EXTERNAL
Exposure time (min)	1 μs
Exposure time (max)	60 sec (external ∞)
Pixel format / max	mono8, mono10, mono12, mono16 / 16 bit
Gain modes	manual, auto
S/N ratio (max)	41.5 dB (dep. on environment)
Dynamic range (max)	74.4 dB (dep. on environment)
Internal memory	1024 MB SDRAM, 160 MB Flash

Feature Set

AOI	yes
LUT	yes
Offset	yes
Binning	yes
Image flip	yes
Shading correction	yes (external)
Defect pixel correction	yes
Sequencer	yes
PoCXP	yes

Housing

Lens mount	M72x0.75
Dimensions (w x h x d)	80 x 80 x 83 mm
Weight	580 g
Operating temperature (housing)	-10 to 60 °C
Ambient humidity	10 to 90 % (non-condensing)
Protection class	IP30
Filter-/Coverglass	Borofloat B270i - AR coating

I/O-Interfaces

Input up to 24V	2 x
Input OPTO	1 x
Output open drain	4 x
I/O RS-232	1 x
Power supply	10 to 25 V (DC)
Power consumption	17 W (dep. on operating mode)

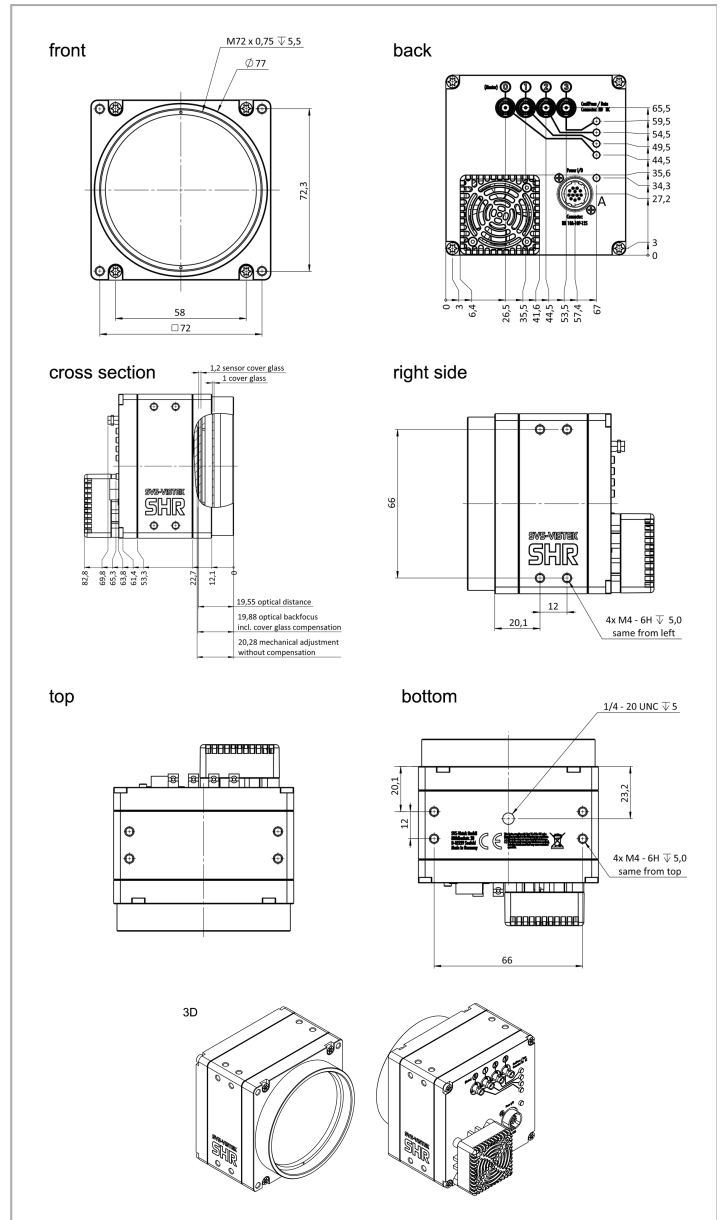

Pinout Mating Connector

Hirose 12 Pin	1	2	3	4	5	6	7	8	9	10	11	12
	VIN -	VIN +	IN 4	OUT 4	IN 1	IN 2	OUT 1	OUT 2	IN 3 +	IN 3 -	OUT 3	OUT 0
	(GND)	(10 V to 25 V DC)	(RXD RS232)	(TXD RS232)	(0 - 24V)	(0 - 24V)	(open drain)	(open drain)	(opto In +)	(opto In -)	(open drain)	(open drain)

Spectral Response *

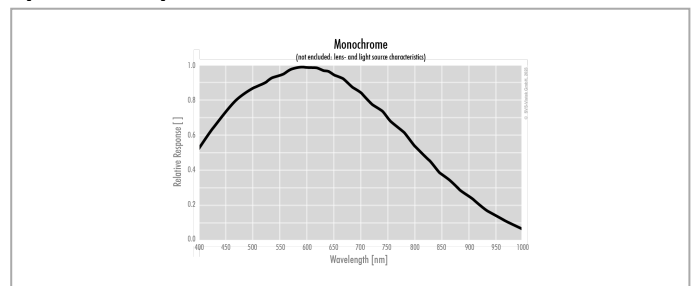

* Sensor data – excludes camera cover- or IR-cut filter characteristics

SVS-VISTEK GMBH

© 2024–2025 SVS-Vistek GmbH

Ferdinand-Porsche-Str. 3 82205 Gilching Germany phone +49 8105 3987-60 info@svs-vistek.com