



Bonito PRO

X-2620B NIR

- APS-H optical format CMOS sensor
- PoCXP
- 4-DIN type connector
- 79.7 fps at full resolution

Speed up your high-resolution application

Robust high-bandwidth camera series

Bonito PRO X-2620B NIR with ON Semi PYTHON 25K NIR runs 79 frames per second at 26.2 MP resolution.

Bonito PRO is Allied Vision's high-bandwidth camera series with a CoaxPress interface. Equipped with four DIN 1.0/2.3 connectors the camera is capable to transmit 25 Gbps via four CXP-6 high-speed connections. Bonito PRO features a rugged, fanless housing design, and powerful feature set – making it the ideal choice for high-definition imaging applications that require high throughput, robustness, and system design-in flexibility.

Easy software integration with Allied Vision's [Vimba Suite](#) and compatibility to the most popular [third party image-processing libraries](#).

See the [Modular Concept](#) for lens mount, housing variants, optical filters, case design, and other modular options. See the [Customization and OEM Solutions](#) webpage for additional options.

Specifications

Interface	CoaXPress (CXP-6) 4 DIN
Resolution	5120 (H) × 5120 (V)
Sensor	ON Semi PYTHON 25K NIR
Sensor type	CMOS
Shutter mode	GS (Global shutter)
Sensor size	Type APS-H
Pixel size	4.5 μm × 4.5 μm
Lens mounts (available)	F-Mount, F-Mount PA, EF-Mount PA, M42-Mount, M42-Mount PA, M58-Mount, M58-Mount PA
Max. frame rate at full resolution	79.7 fps
ADC	10 Bit
Non-volatile memory (Flash)	1024 KB

Imaging performance

Imaging performance data is based on the evaluation methods in the EMVA 1288 Release 3.1 standard for characterization of image sensors and cameras. Measurements are typical values for NIR models measured without optical filter.

Quantum efficiency at 529 nm	55 %
Quantum efficiency at 850 nm	34 %
Temporal dark noise	20.7 e ⁻
Saturation capacity	8100 e ⁻
Dynamic range	51.6 dB
Absolute sensitivity threshold	21.4 e ⁻

Output

Bit depth	10-bit
Monochrome pixel formats	Mono8, Mono10

General purpose inputs/outputs (GPIOs)

TTL I/Os	1 input, 2 outputs
Opto-isolated I/Os	1 input, 2 outputs

Operating conditions/dimensions

Operating temperature	-20 °C to +70 °C housing (without condensation)
Power requirements (DC)	24 VDC; PoCXP
Power consumption	External power: 15 W at 24 VDC Power over CoaXPress: 15 W
Mass	500 g (with F-Mount)
Body dimensions (L × W × H in mm)	114.9 × 70 × 70 (with F-Mount and connectors)

Quantum efficiency

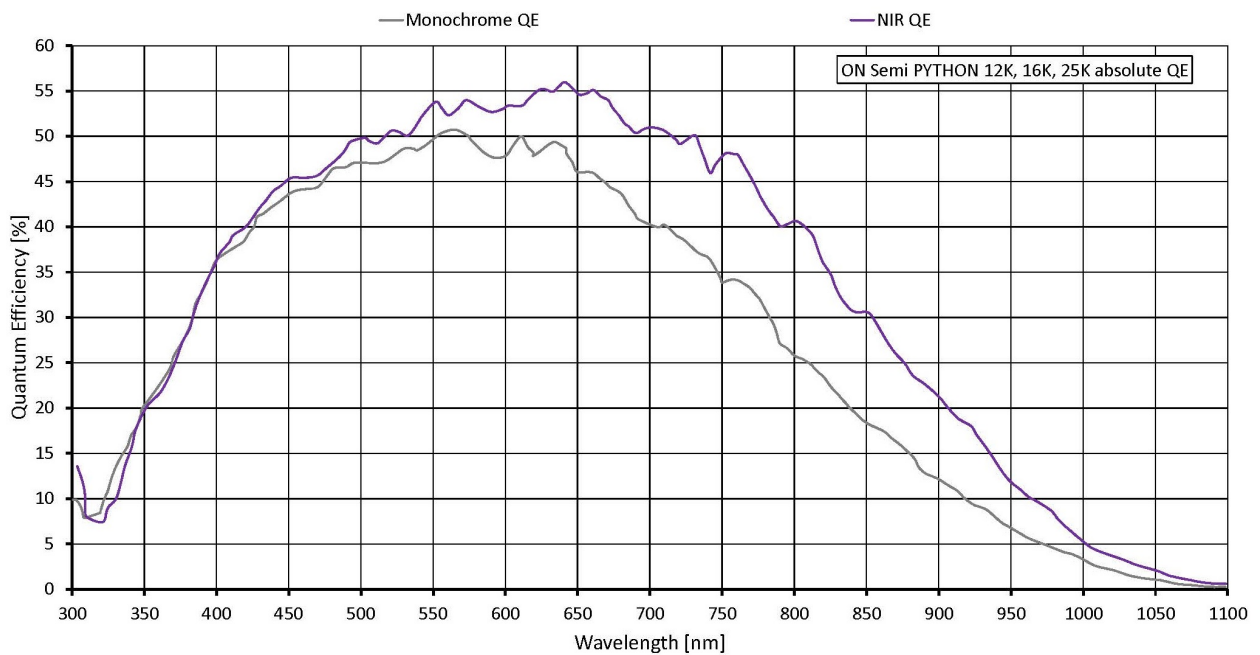

Features

Image optimization features:

- Auto gain (manual gain control: 0 to 22 dB)
- Auto exposure (manual exposure control: 1 μ s to 1 s)
- Binning (horizontal and/or vertical), (sum or average)
- Decimation X/Y
- Gamma correction
- Look-up tables
- Defect Pixel Correction
- Fixed Pattern Noise Correction

Camera control features:

- Multiple region of interest
- Sequencer Control
- Trigger over CoaXPress
- EF lens control (order option -18)
- Storable user sets
- Sync out modes: Trigger ready, input, exposing, readout, imaging, strobe, GPO
- Temperature monitoring (main board and sensor board)

Technical drawing

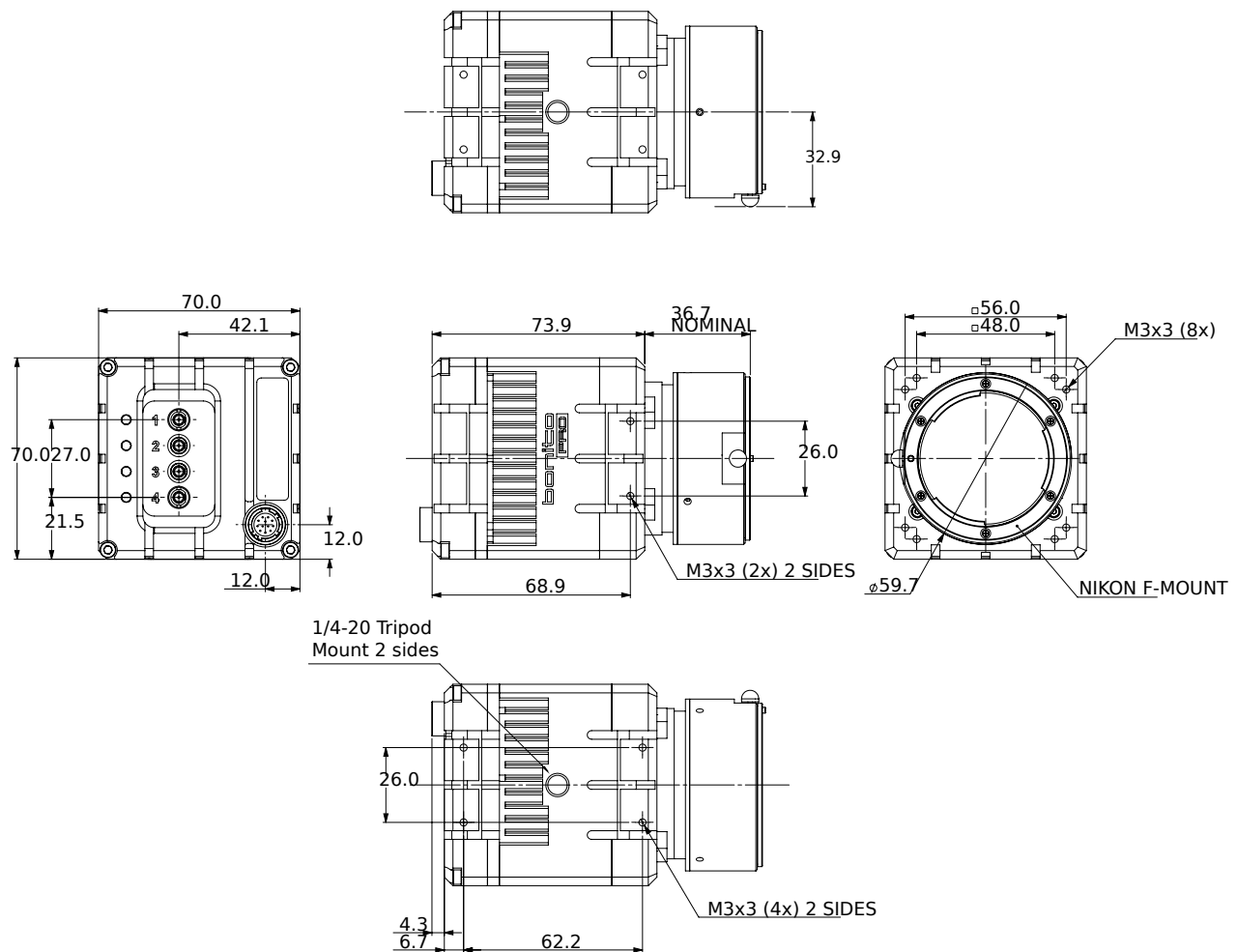

Applications

Bonito PRO X-2620B NIR is ideal for a wide range of applications including:

- Automated Optical Inspection of flat panel displays, PCB/electronics, printings
- 2D/3D Surface Inspection (for example, glass)
- Aerial imaging