



FX0 25GigE

# fxo530C25GE

With the modern Sony Pregius S sensor, the FX0 25GigE offers outstanding image quality together with an economical high-performance interface. Distances up to 10,000 meter are supported. The control is transparent to GigE Vision.

The camera is equipped with RDMA (Remote Direct Memory Access) technology. With this technology, it is possible to transfer image data directly to the main memory of a PC. This does not stress the operating system and CPU, significantly improving reliability and performance and greatly reducing latency/response time. The CPU can perform other tasks due to this relief.

The solid, CNC-milled housing offers excellent temperature management gives excellent image homogeneity.

The large image memory supports the rapid triggering of image sequences regardless of the network load.

The fan can be fully deactivated via software and features a hermetic seal that isolates airflow from internal components, ensuring compatibility with critical cleanroom environments. Optional heatsinks help keep your camera in optimal operating conditions.

## Technical Highlights

- Excellent homogeneity across the entire image
- Thermally optimized, milled aluminum housing
- 25GigE Interface (+RDMA)
- Integrated 4-channel LED strobe controller
- ROI, lookup tables
- C mount
- IO interface with 2xIN, 4xOUT, Opto and RS232
- with SafeTrigger, programmable timers, logic functions (PLC) and sequencer



**25** **GigE**  
**+RDMA**

**LED**  
4 INTEGRATED  
LED CONTROLLERS

**SEQ**  
INTEGRATED  
SEQUENCER

**STT**  
SAFE TRIGGER  
TECHNOLOGY

**PLC**  
PROGRAMMABLE  
LOGIC CONTROL

## Specifications

Resolution [MP]	24.6 MP
Resolution (h x v)	5328 x 4608 px
Frame rate(max.)	96 fps
Chroma	color
Interface	25GigE (SFP28)

## Sensor

Sensor	IMX530AAQJ
Manufacturer	Sony
Sensor type	Area CMOS
Shutter type	global shutter
Sensor size (h x v)	14.6 x 12.63 mm
Optical diagonal	19.3 mm
Sensor format	19.3mm (Type 1.2)
Pixel size (h x v)	2.74 x 2.74 $\mu\text{m}$

## Camera

Exposure modes	MANUAL;AUTO;EXTERNAL
Exposure time (min)	4 $\mu\text{s}$
Exposure time (max)	60 sec (external $\infty$ )
Pixel format / max	bayer8, bayer12 / 12 bit
Gain modes	manual, auto
S/N ratio (max)	39 dB (dep. on environment)
Dynamic range (max)	72 dB (dep. on environment)
Internal memory	4096 MB SDRAM, 128 MB Flash

## Feature Set

Manual white balance	yes
Automatic white balance	yes
AOI	yes
LUT	yes
Offset	yes
Binning	yes
Image flip	yes
Sequencer	yes
RDMA RoCE v2	yes
PTP	yes
Color Transformation Control	yes

## Housing

Lens mount	C-Mount
Dimensions (w x h x d)	50 x 50 x 100 mm
Weight	320 g
Operating temperature (housing)	-10 to 60 °C
Protection class	IP30
Filter-/Coverglass	IR-Cut 680

## I/O-Interfaces

Input up to 24V	2 x
Input OPTO	1 x
Output open drain	4 x
I/O RS-232	1 x
Power supply	10 to 25 V (DC)
Power consumption	17.5 W (dep. on operating mode)

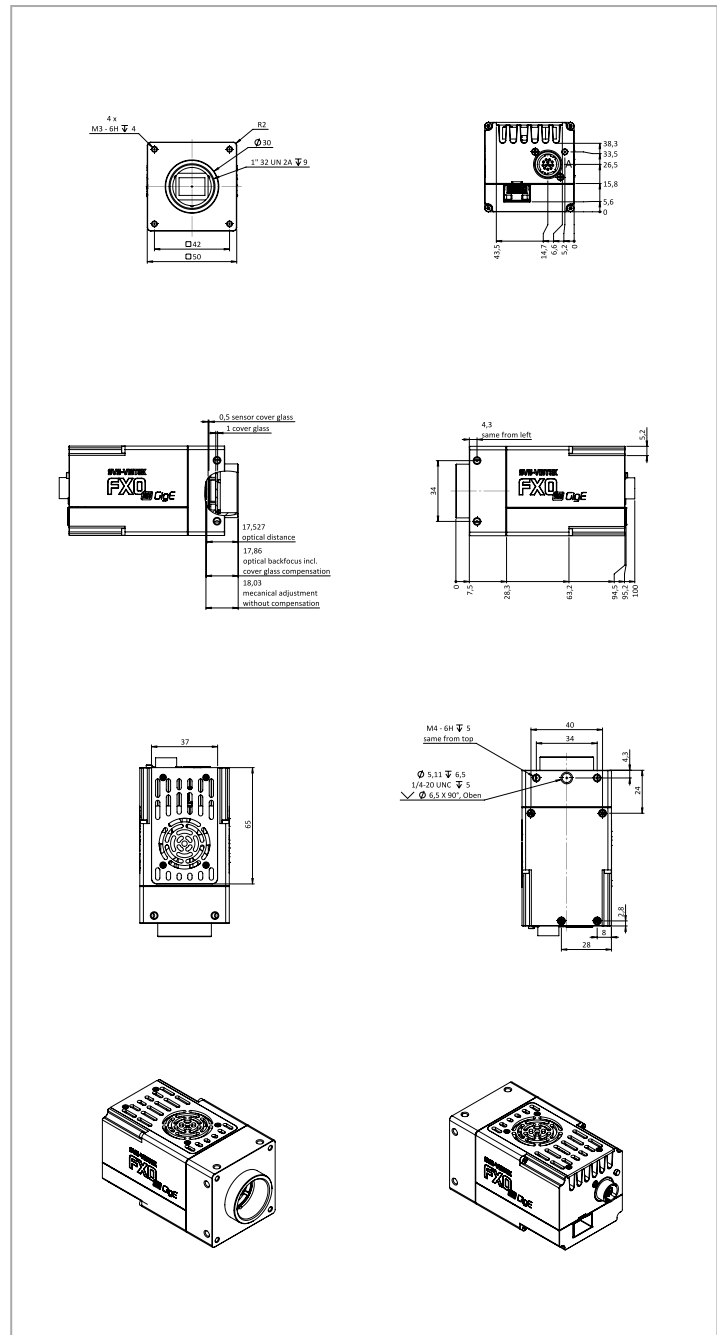

## Pinout Mating Connector

Hirose 12 Pin	1	VIN - (GND)	7	OUT 1 (open drain)
	2	VIN + (10 V to 25 V DC)	8	OUT 2 (open drain)
	3	IN 4 (RXD RS232)	9	IN 3 + (opto In +)
	4	OUT 4 (TXD RS232)	10	IN 3 - (opto In -)
	5	IN 1 (0 - 24V)	11	OUT 3 (open drain)
	6	IN 2 (0 - 24V)	12	OUT 0 (open drain)

## Spectral Response \*

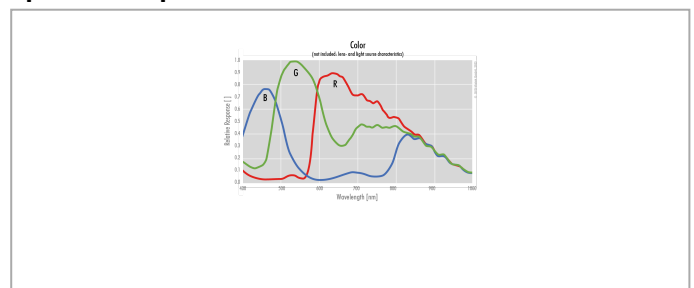

\* Sensor data – excludes camera cover- or IR-cut filter characteristics

**SVS-VISTEK GMBH**

© 2024–2025 SVS-Vistek GmbH

Ferdinand-Porsche-Str. 3 82205 Gilching Germany phone +49 8105 3987-60 info@svs-vistek.com