

Alpha 3D Scanner L

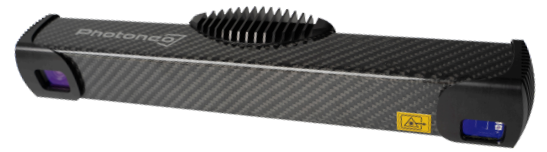

Datasheet

3D sensing technology	Structured Light		
Output data	3D points (x y z), Normals (x y z), Depth Map (z), Texture (grayscale intensity), Confidence		
Depth map resolution	1.5Mpix (1440 x 1080)		
Scanning range (near - sweet - far)	870 - 1239 - 2150 mm		
Scanning area (sweet spot)	1091 x 761 mm		
Scanning Distance (mm)	Near	Sweet	Far
	870	1239	2150
Relative distance accuracy (‰)	2.00	2.00	2.00
Global planarity (mm)	0.70	0.96	1.60
Local planarity (mm)	0.30	0.50	1.00
Temporal noise (mm)	0.08	0.17	0.38
Point-to-point distance (mm)	0.55	0.79	1.37
Acquisition time	From 240 ms		
Scanning time	From 450 ms		
Dimensions	439 x 68 x 86 mm		
Baseline	350.0 mm		
Weight	950 g		
Temperature working range	Full:	0 - 40 °C (32 - 104 °F)	
	Optimal:	22 - 25 °C (71.6 - 77 °F)	
Power	PoE or 24V		
Data connection	1 Gbit Ethernet		
IP rating	IP65		

These parameters are valid at [standard conditions](#).

For operation and installation instructions, refer to the User Manual and CAD models available at: <https://photoneo.com/kb/device-resources>



Scanning Volume

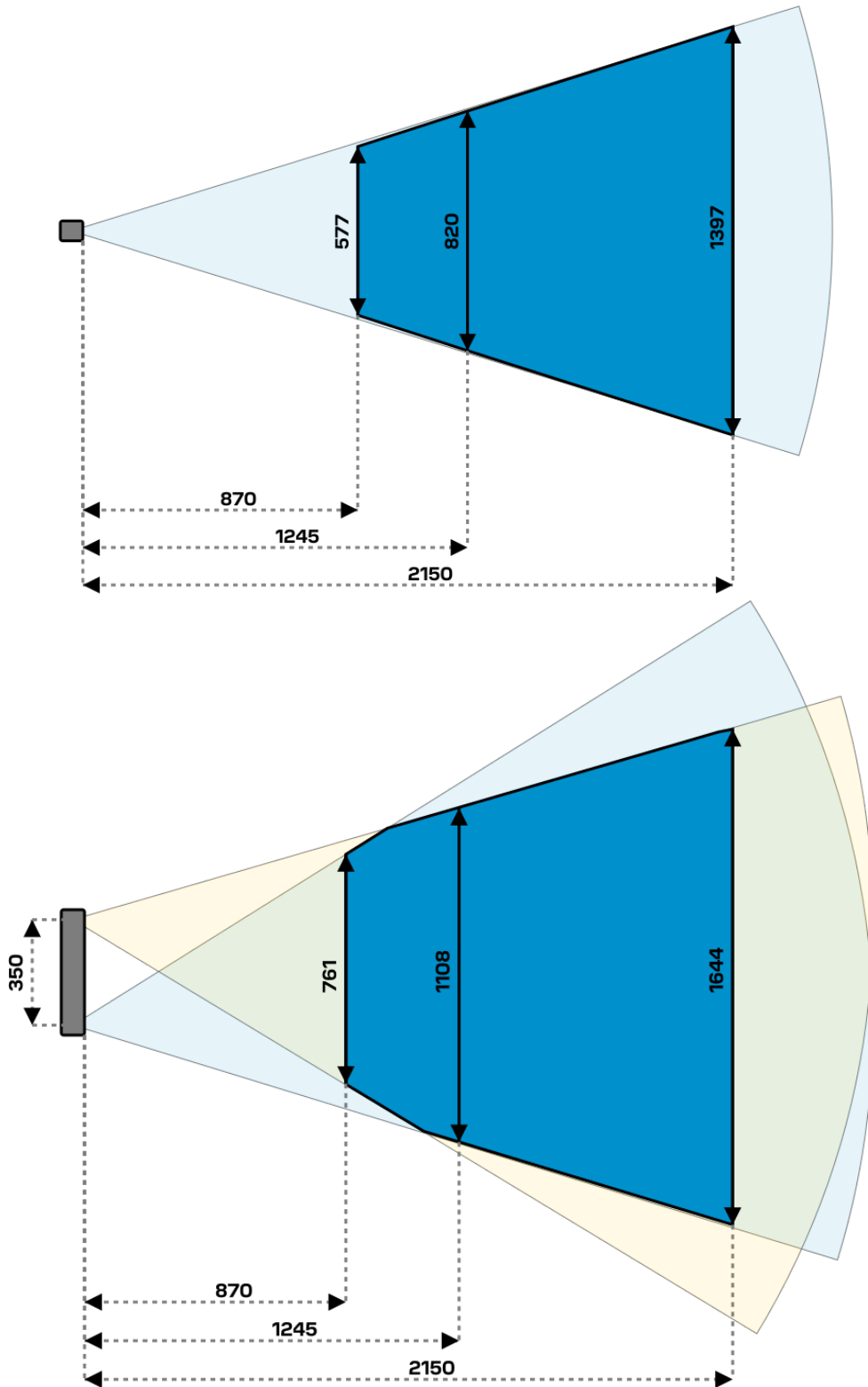

Performance Graphs

Planarity and temporal noise Alpha 3D Scanner L

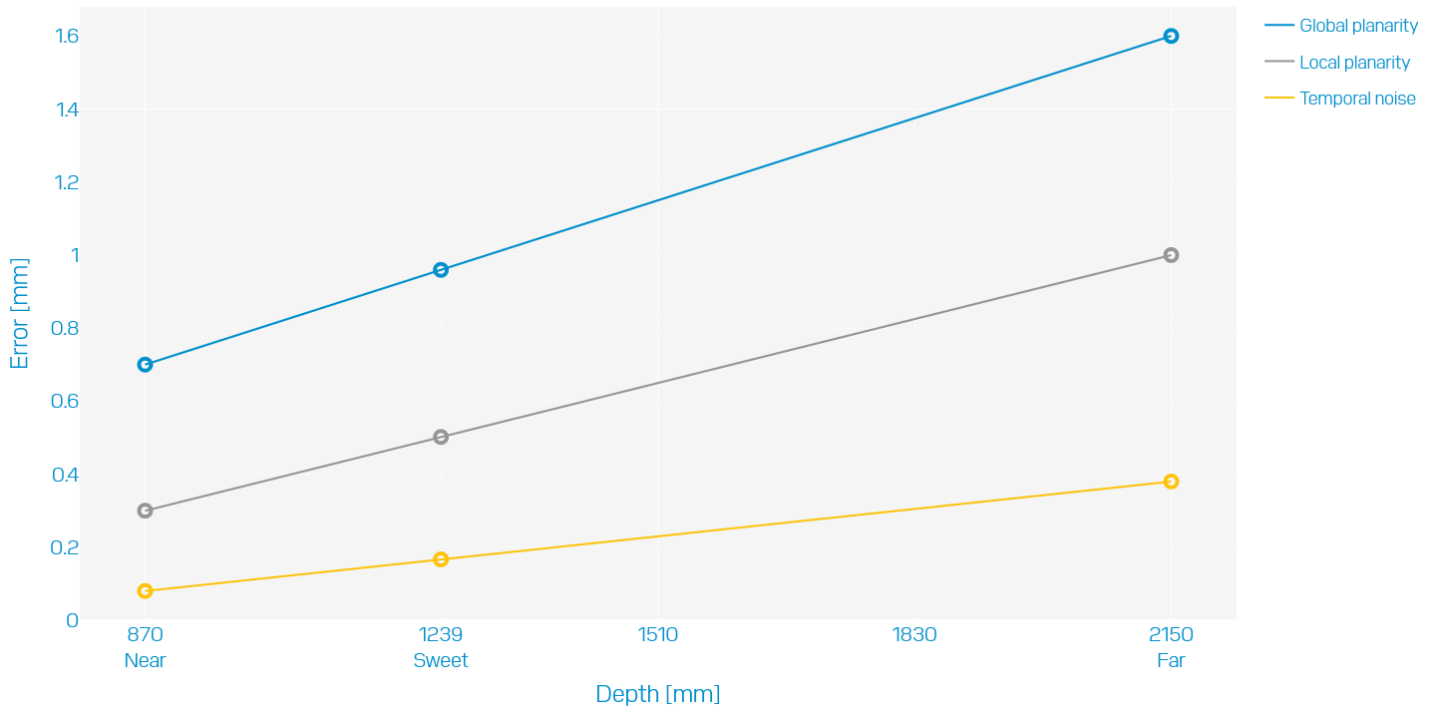

Technical Drawing

Bottom View: Mounting Plate

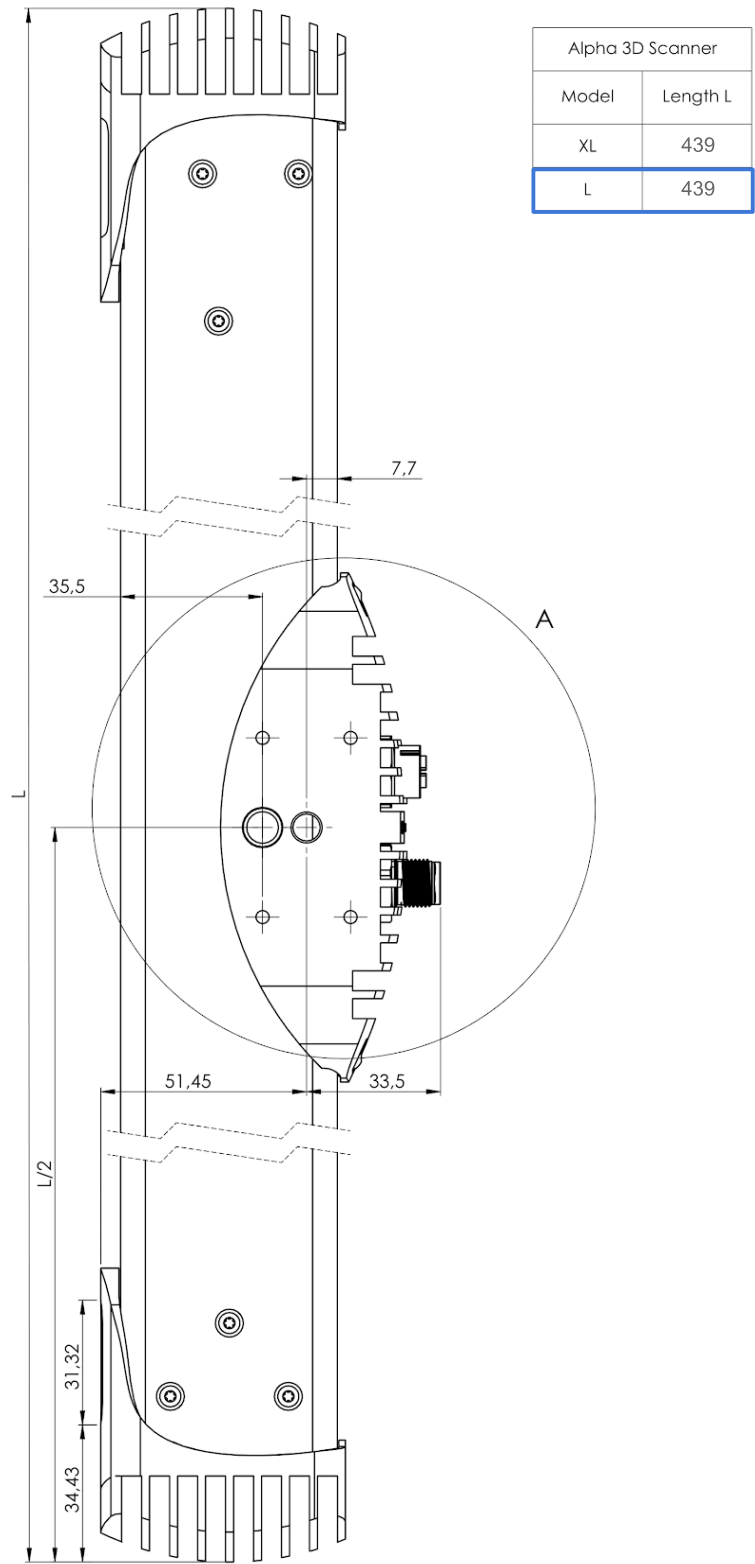

Bottom View: Detail A

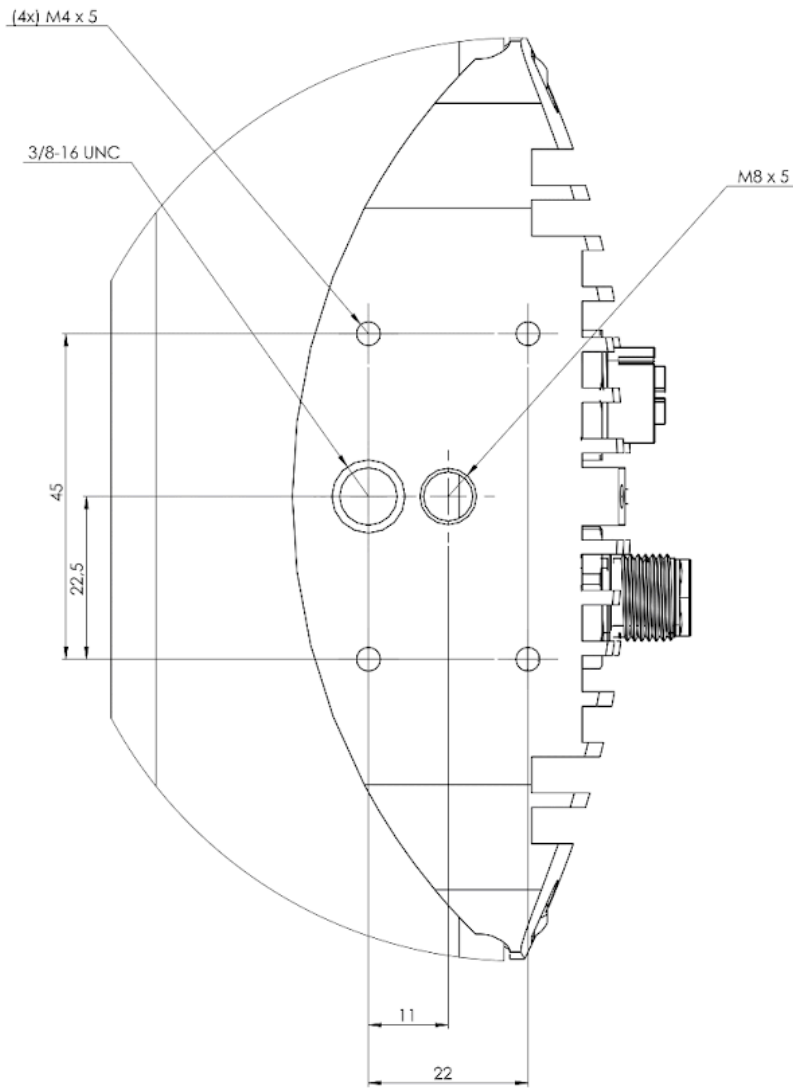

DETAIL A

Front View: Projection Unit and Camera Unit

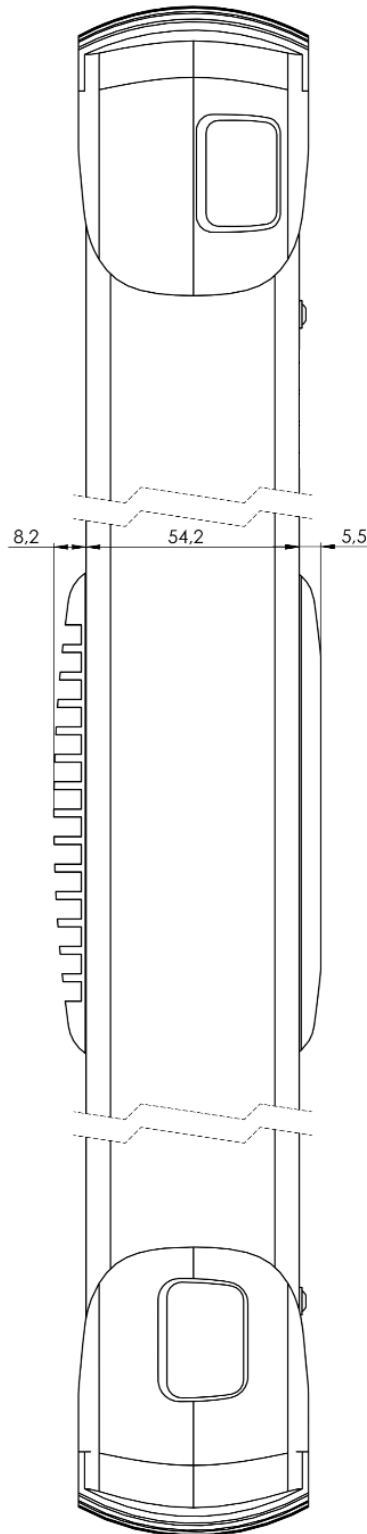

Parameter Definitions

The datasheet defines several performance properties of a Photoneo 3D Sensor. A population of production devices is characterized by the typical and maximum observed values, given a properly maintained device. The typical value represents the performance of the average device, while the maximum value is the upper limit of the population. Some of the performance properties were determined theoretically from a model.

The table values represented in the datasheet are the maximum values. The graphs show both maximum and typical values.

Standard Conditions

The *Standard Conditions* refer to a stable environment for measurements, characterized by homogenous ambient light, excluding strong or flashing light sources other than the verified device, a stable humidity and stable room temperature (ISO 554), and the absence of shocks or shaking.

3D Sensing Technology

Photoneo 3D Sensor either uses sequential structured light technology or Parallel Structured Light Technology. More information can be found in the section [Objects Suitable for Scanning](#) of the Photoneo 3D Sensors - User Manual.

Output Data

Depending on the device used for scanning, the output data structure can differ.

- 3D points (x y z)
 - a. Floating numbers depicting the position of a 3D point in a given coordinate frame. The default coordinate frame has its origin in the 2D camera with the Z-axis towards the scene, the X-axis continuing to the right of the device, and the Y-axis facing downward.
- Normals (x y z)
 - a. The normal vector for each 3D point can also be calculated. The normal vector is perpendicular to the area surrounding the point.
- Depth Map (z)
 - a. The “depth” of a point is the absolute 3D distance from the image sensor to the measured point (the ray of light that hits the surface of the object). The DepthMap is, therefore, always in the camera coordinate system and corresponds to the Z coordinate value in the point cloud.
- Color Image (RGB)
 - a. A 2D RGB texture is available on the MotionCam-3D Color in both Scanner and Camera modes at different resolutions.
- Texture (grayscale/RGB)
 - a. A 2D texture (LED, Computed, Laser, Focus, Color).
- Confidence (float)
 - a. For each measured 3D point, the “confidence” value expresses certainty about the accuracy of the point measurements. For example, a confidence value of 0.12 means that the estimated error for a point measurement is 0.12 mm. This value is based on a heuristic method that considers the light conditions for each pixel.



Scanning Distance

The *Scanning Distance* is the distance between the sensor and the verification object. It can be expressed in millimeters or simplified into terms such as near, sweet, or far to describe the minimal, ideal or maximal distance of the scanned object from the device.

Scanning Range (near - far)

The *Scanning Range* consists of 2 values, which represent the minimal (near) and maximal (far) distance of the scanned object from the device in order to perform the 3D reconstruction. The volume bounded by intersecting planes at near/far distances is called a calibration volume, and it is determined by the model of the Photoneo 3D Sensor.

Optimal Scanning Distance (sweet spot)

Denotes the focus distance of the primary 2D camera (inside a Photoneo 3D Sensor) at which, theoretically, the best scanning results can be obtained.

Scanning Area (sweet spot)

Size of the area that is covered by the field of view at the optimal scanning distance (sweet spot).

Operation Mode / Scene (MotionCam-3D devices only)

MotionCam-3D (Color) devices are able to switch between a Camera (Dynamic) mode and a Scanner (Static) mode. In the Camera mode, the device is able to capture objects in motion, or the device itself can be moving without causing any motion blur. The Scanner mode requires the devices as well as the scene to be static during scanning. Additionally, all devices also support a 2D mode that outputs only 2D texture data.

Relative Distance Accuracy

The *Relative Distance Accuracy* expresses the accuracy of the measured distance between 2 points in a scene, divided by their true/reference distance. Distances are measured for points lying at a particular depth from the device. The provided value is the 68th percentile of measured relative errors.

The performance parameters are valid at [Standard Conditions](#) for a maintained device using marker based Maintenance Tool. For the devices maintained only via Autonomous Maintenance the RDA value may increase by up to 0.2%. For every 10 °C deviation of the ambient temperature outside the Standard Conditions, the RDA value may increase by up to 0.15%.

Global Planarity

The *Global Planarity* refers to the root mean square error (i.e., standard deviation) of the plane fitted to the point cloud of the planar surface that covers the whole field of view and is parallel to the device body.

Local Planarity

The *Local Planarity* refers to the root mean square error (i.e., standard deviation) of the plane fitted to the local planar surface (approx. 50x50 points) parallel to the device body. An average of the individual measurements is computed over the patches covering the field of view.



Temporal Noise

The *Temporal Noise* represents the repeatability of the point-wise depth measurements (i.e., standard deviation) aggregated over the whole field of view in a particular depth. This property expresses the ability of the sensor to capture local surface details.

Point-to-Point Distance

The *Point-to-Point Distance* is the average lateral distance between the closest neighboring points in the point cloud at the specified distance from the sensor. It can also be interpreted as the average diameter of a patch associated with a single 3D point observed at a specific distance from the sensor.

Acquisition Time

The Acquisition Time is the active duration required to illuminate the scene and capture the raw data. This value may not correspond to the value displayed in the frame information.

Scanning Time

The total *Scanning Time* is the sum of the time required for acquisition, computation, and transfer.

Depth Map Resolution

The *Depth Map Resolution* defines the number of pixels of the primary 2D camera used for 3D sensing.

Color Image Resolution

The *Color Image Resolution* refers to the number of pixels of the secondary RGB camera. The resolution of the RGB camera can be set to one of the predefined values. Note that the *Color Image Resolution* is independent of the *Depth Map Resolution*.

Frames Per Second

The *Frames Per Second* (FPS) expresses the maximum achievable frame rate, i.e., the number of 3D scans per second. The FPS value can be affected by the selected profile or parameters.

Dimensions

The *Dimensions* are expressed in 3 values that represent the length, height, and depth of the device in millimeters, respectively.

Baseline

The *Baseline* is the distance between the primary 2D camera and the projection unit.

Weight

Weight of the device (without accessories).

Color Camera Angle

The angular coverage of the secondary RGB camera, defining the extent of the scene captured in a single image.

Main Camera Angle

The angular coverage of the primary 2D camera used for 3D sensing, determining the portion of the scene included in the scan.

Main Camera Field Of View

The Field of View (FOV) of the primary 2D camera, expressed in degrees, representing the horizontal and vertical span visible at a given distance.

Temperature Working Range

The *Temperature Working Range* refers to the operational range of temperatures of the Photoneo 3D Sensors. To achieve the optimum scanning performance, the sensor needs to be thermalized within the optimal temperature range (standard atmospheric conditions defined by ISO 554).

Projection Unit Laser Color

The *Projection Unit Laser Color* describes the color of the laser used in the sensor's projection unit. The type of the projection unit can have an effect on the scanning performance on specific scenes and objects.

Power

The device can be powered using a Power over Ethernet injector or a 24V adapter. Further information can be found in photoneo.com/kb/device-manual

Processing Unit

The processing unit for Photoneo 3D Sensors is the NVIDIA Jetson TX2. This unit performs all 3D data computations directly on the device, which helps to reduce external computing demands

IP Rating

Indicates the level of protection against solid particles and liquids, as defined by IEC 60529. The first digit rates dust protection, the second rates water resistance; higher numbers mean greater protection. For more information, visit : <https://www.iec.ch/ip-ratings>

Data Connection

It is recommended that the device be connected to a 1 Gbit network to ensure sufficient data flow.



01-2026-v1.2

Contact us

Headquarters:

Zebra Technologies Slovakia s.r.o.

Plynárenská 6

821 09 Bratislava,

Slovakia

Technical support

Contact us at the [Help Center](#).

Visit Photoneo support pages at www.photoneo.com/support.

Orders and inquiries:

photoneo-sales@zebra.com

photoneo-sales-us@zebra.com



All rights reserved.

Copyright © 2025 by Zebra Technologies Slovakia s.r.o., Bratislava, Slovakia

Photoneo®, PhoXi® Control, PhoXi® 3D Scanner, MotionCam-3D are registered trademarks of Zebra Technologies Slovakia s.r.o.